



Pipes for Life

Qual-PEX Crimp System



Plumbing &
Heating
Installation
Brochure

NEW

NEW



Over 45 years serving the Irish Plumbing Industry

Sleek, Affordable, Fast, Efficient

SAFE

www.pipelife.com

Contents

PAGE

Qual-PEX Crimp Guarantee	1
Other Products in the Qual-PEX Crimp Range	1
Testimonials	1
The Benefits of the Qual-PEX Crimp System	2
Qual-PEX Crimp Fitting	2
Qual-PEX Barrier Pipe	3
Qual-PEX Crimp Fitting 1/2" & 3/4"	4
Qual-PEX Clamp Tool	4
Qual-PEX Crimp Jointing Guidelines	5
Pipelife Polymer Threaded Connections	8
Qual-PEX Crimp Tap Connections	8
Installing Qual-PEX Crimp System in Concrete/Masonry	9
Feeding Qual-PEX Pipe Through Timbers	9
Qual-PEX Crimp System - Approvals and Testing	10
Expansion and Contraction	10
Pipe Clipping	10
Minimum Bend Radii	11
Storage and Handling	11
UV Exposure	11
Freezing Conditions.....	11
Working Conditions.....	11
Circulating Main Installations	12
Hot Water Installations.....	12
Boiler & Cylinder Connections	13
Pressure Testing	13
Installation Checklist for the Complete System	13
Some Questions Most Often Asked	
About Qual-PEX and the Crimp System	15
Qual-PEX CRIMP System Guarantee	16

Qual-PEX CRIMP System Guarantee

Pipelife's guarantee on the Qual-PEX CRIMP system against manufacturing defects is a minimum of 50 years.

The guarantee remains valid provided that the pipe and fittings are installed as per our recommended installation guidelines outlined above and that the products installed were not damaged before, during or after installation.

Guarantee only applies when Qual-PEX Crimp and Qual-PEX pipe is used.

N.B. Qual-PEX Crimp fittings are designed exclusively for use with Qual-PEX pipe, Qual-PEX insulated pipe and Qual-PEX Pipe-in-pipe

Other Products in the Qual-PEX Crimp System Range



Qual-PEX



Qual-PEX ECO



Qual-PEX Pipe-in-Pipe



Qual-PEX Crimp Fittings

Testimonials

“Tool fits into tight spaces. Crimp fitting very neat looking compared to compression. Crimp Tee v compression Tee time trial, 8 crimp Tees installed compared to 3 compression Tees. Delighted with the Qual-PEX Crimp system. Will be using it in the future.”

Mathew Keogh, Plumber, Dublin.

“Very happy with how simple this system is. No inserts needed, huge cost saving on many levels, faster, cheaper than MLCP crimp, much lighter for transportation, will be widely available. No confusion on what profile, what jaws, availability of the fittings. Love the sleek finish. Only tools needed is a cutters and a clamp tool. This is a game changer”

Trevor Hill, Hill Heating & Plumbing, Cork.

It took one senior plumber and apprentice 2 and half days to first fix one house with multilayer pipe. With the Pipelife Qual-PEX Crimp System we first fixed one house in a little over one day. We are delighted with the speed and ease of the fittings. We will continue to use our system for this site with Qual-PEX. Also the 1/2" & 3/4" nail on clips fit perfectly around the fittings.

Thomas Donegan, Ballyshane, Rathangan, Co. Kildare.



Example of an installation in Monstererevin, Co Kildare. Saving on labour time is 50% over multilayer.



Example of an installation in Kinsale, Co. Cork. Saving on labour time is 60% over compression.

The Benefits of the Qual-PEX Crimp System.

S.A.F.E. : Sleek, Affordable, Fast, Efficient.

- ✓ No Expensive tooling – theft of other crimp tools a major problem, no insurance.
- ✓ No confusion over jaw profiles and wall diameter etc.
- ✓ No problems associated with mixing and matching systems.
- ✓ No difficulty pulling through joists.
- ✓ No issue fitting in studwork: Much smaller and neater.
- ✓ No risk of nut loosening behind stud wall Compression elbow v Qual-PEX Crimp System.
- ✓ No working with heavy press machines on site all day.
- ✓ No battery charging required
- ✓ No water/metal contact. Completely corrosion resistant.
- ✓ No joint preparation required – FAST.
- ✓ No fitting required in base as per conduit shoe v compression elbow on copper:
- ✓ Availability of manufacture's rep's.
- ✓ Wide network of Qual-PEX stockists – full range of multilayer not stocked in many merchants.
- ✓ Speed.
- ✓ Approval from engineers.
- ✓ Tooling up for the Qual-PEX Crimp System is inexpensive. This is a major benefit.
As your company expands, no forking out thousands of Euro on tooling up.
- ✓ Simple, controlled and accurate joint – every time.
- ✓ 50 Year Guarantee.

Qual-PEX Crimp Fitting

Pipelife have developed an extensive range of quality crimp fittings which have complete compatibility with Qual-PEX pipe. The airforce grade annealed aluminium protective metal sleeve is precisely attached to each fitting during production and is designed to provide a unique metal reinforced leak free joint.

The polymer fittings are made from a high performance thermoplastic. The polymer fittings can withstand high temperatures and are corrosion resistant. Users of Qual-PEX Crimp fittings will find installation much quicker, easier and more economical than other available systems.



Qual-PEX Barrier Pipe

Qual-PEX cross-linked poly-ethylene barrier pipe from Pipelife is truly a first in this generation of thermoplastic pipes – being the first PEX pipe ever to have been approved to the BS 7291 kitemark and also holding WRAS and Irish Agrément Board approvals.

Pipelife Qual-PEX barrier pipe is produced in 1/2", 3/4" and 1" sizes.

(Qual-PEX Crimp fittings are available in 1/2" & 3/4")

- ✓ Qual-PEX - the flexible tan coloured crosslinked polyethylene plumbing pipe.
- ✓ Qual-PEX has been developed, tested and approved for hot and cold water services, and central and underfloor heating systems. Qual-PEX is designed to suit Pipelife (Qual-PEX Crimp, Tectite and Qual-FIT) pushfit fittings and standard Brass Compression Fittings and Manifolds.
- ✓ Qual-PEX is available in the following sizes in both lengths & coils.
Irish Sizes:- 1/2" (14.7mm), 3/4" (21.0mm) and 1" (27.4mm).
- ✓ Qual-PEX includes an EVOH Barrier Layer. Barrier complies with DIN 4726.
- ✓ Qual-PEX is rigid enough to minimise sag with pipe runs looking neat, tidy and professional.
- ✓ Qual-PEX is flexible enough to be cabled through awkwardly placed holes under flooring and threaded behind partition walls and through ducts.
- ✓ Qual-PEX enables the installer to undertake faster, easier and more cost-effective installation. Independent tests show installation time savings of up to 40% compared with traditional plumbing materials.
- ✓ Qual-PEX is also approved for use by:-
IAB (Irish Agrément Board).
- ✓ Qual-PEX barrier pipe incorporates an EVOH oxygen diffusion barrier layer sandwiched within the wall of the pipe, which protects the layer from physical and UV damage. The EVOH layer renders the pipe virtually impervious to gases. Qual-PEX barrier pipe improves the performance of sealed central heating systems by reducing the risk of pressure drops caused by a vaporisation of water and corrosion which can occur in a boiler's heat exchanger.
- ✓ Qual-PEX can be purchased pre-insulated (Qual-PEX Eco) and in corrugated ducting (Pipe-in-pipe).



Qual-PEX CRIMP FITTING 1/2" AND 3/4"



3095210040 1/2" Qual-PEX Crimp Elbow
3095210045 3/4" Qual-PEX Crimp Elbow



3095210050 1/2" Qual-PEX Crimp Stop End
3095210085 3/4" Qual-PEX Crimp Stop End



3095210055 1/2" Qual-PEX Crimp Equal Tee
3095210075 3/4" Qual-PEX Crimp Equal Tee



3095210070 3/4" x 3/4" x 1/2" Qual-PEX Crimp Reducing Tee
3095210090 3/4" x 1/2" x 1/2" Qual-PEX Crimp Reducing Tee
3095210100 3/4" x 1/2" x 3/4" Qual-PEX Crimp Reducing Tee



3095210060 1/2 Qual-PEX Crimp Connector
3095210065 3/4" Qual-PEX Crimp Connector



3095210080 3/4" x 1/2" Qual-PEX Crimp Reducer



3095210105 1/2" Qual-PEX Crimp BSP Straight Tap Connector
3095210110 3/4" Qual-PEX Crimp BSP Straight Tap Connector



3095210115 1/2" Qual-PEX Crimp BSP Male Coupling



3095210120 1/2" Qual-PEX CRIMP Tool
3095210125 3/4" Qual-PEX CRIMP Tool

Qual-PEX Clamp Tools

Pipelife clamp tool has been engineered to ensure a simple, controlled, accurate joint every time. This long life quality tool has a "head" design which permits easy access and alignment. The Qual-PEX design needs no "on-site" adjustment and guarantees consistent results. The Qual-PEX Clamp Tool is available in two sizes, 1/2" and 3/4".

(Pipelife Clamp Tools are supplied with a 12 month guarantee from date of purchase.)

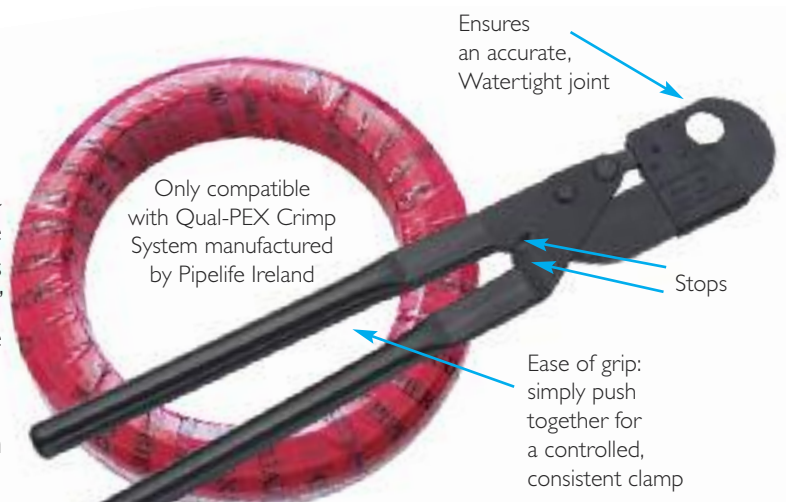

Qual-PEX Crimp Jointing Guidelines



A depth marker can be found every 15mm on Qual-PEX pipe.

1. Cut pipe squarely at the Qual-PEX Crimp depth marker with Qual-PEX pipe cutter.



2. Insert the pipe into the fitting until the aluminium sleeve is in line with the next depth marker. **1/4 twist pipe onto fitting to ensure a sure fit. Ensure you push the pipe all the way (15mm) into the shoulder of the fitting.**



3. Clamp-Hold-Release
Clamp approximately 2mm in from the end of the fitting, close the tool handles completely to the stops provided, and hold firmly for around 2 seconds, then release.



4. The process of installing the system is clean and quick, leaving a watertight mechanical joint.



* Depth markers should only be used for Qual-PEX Crimp fitting and not compression or pushfit.

Installation Guide

Treat Qual-PEX installations in a tradesman-like manner.
Use the complete Qual-PEX System – clamp tools, pipe, fittings, etc.

Preparation of Pipe

- (a) Cut the pipe to length squarely and cleanly using only approved pipe cutters.
- (b) Allow enough length for contraction / expansion (minimum 10mm per meter). See expansion and contraction on page 10.
- (c) When measuring, allow 15mm of pipe for each fitting. Alternatively, use Qual-PEX Crimp depth marker which is found every 15mm on Qual-PEX pipe.
- (d) Ensure the pipe is clean and free from grease or any other contamination.
- (e) Ensure the pipe has no kinks, buckled sections, deep surface scores, etc.

Position of Fittings

- (a) Pre-position fittings correctly on the pipe to achieve alignment with all other pipework prior to clamping.
(15mm "in" from end of fitting)

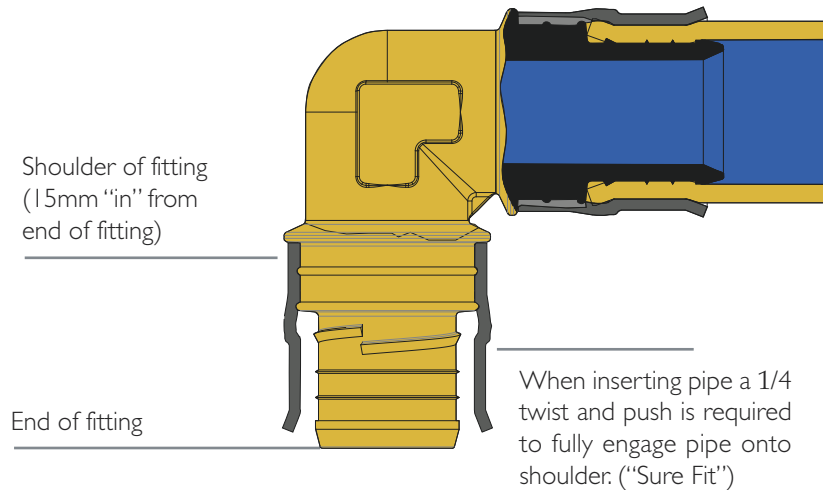

- (b) Fully insert (push home to shoulder) the pipe into the Qual-PEX Crimp fittings.

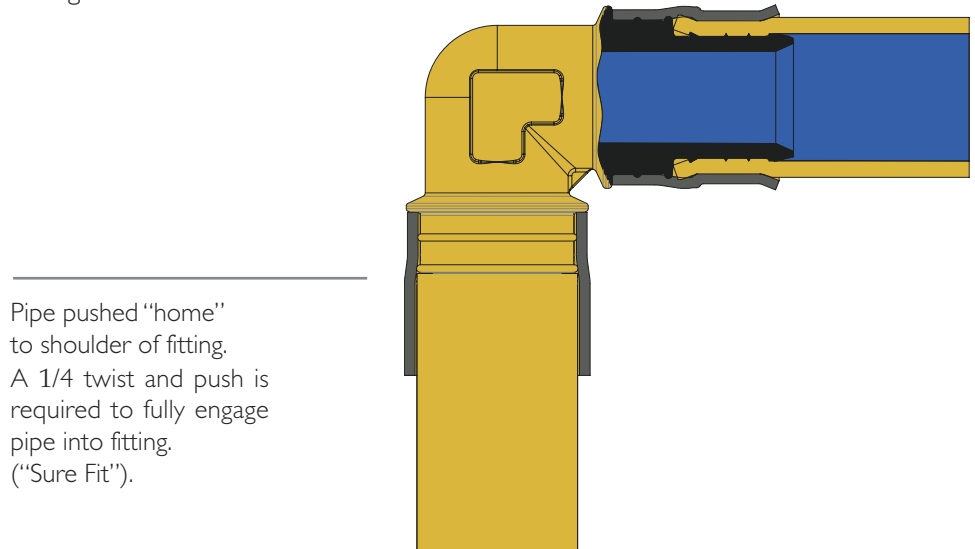

Clamping Qual-PEX Fittings

- (a) Position the Qual-PEX clamp tool squarely and approximately 2mm in from the end of the factory fitted reinforcing clamp ring

Correct Clamp
Tool Position

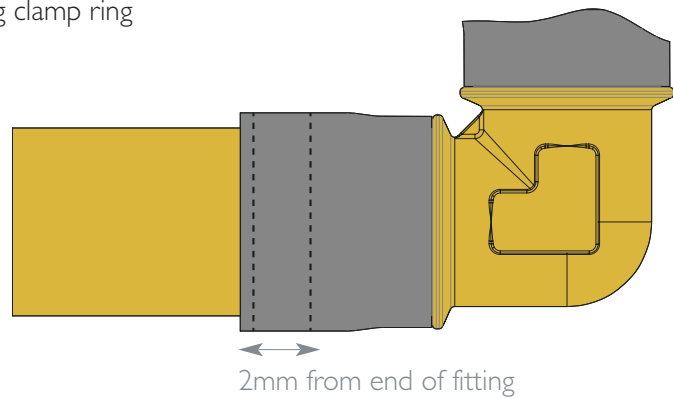

- (b) Close clamp tool handles completely (to the stops provided), hold fully closed, for approximately 2 seconds, then release.
- (c) A good clamp will produce a “flare” at the end of the reinforcing ring. The “flare” shows that the full clamp width (8mm) has been applied to the joint - and the designed result achieved. (It is important that a full clamp width is achieved).

Correct Appearance
of a Completed Joint

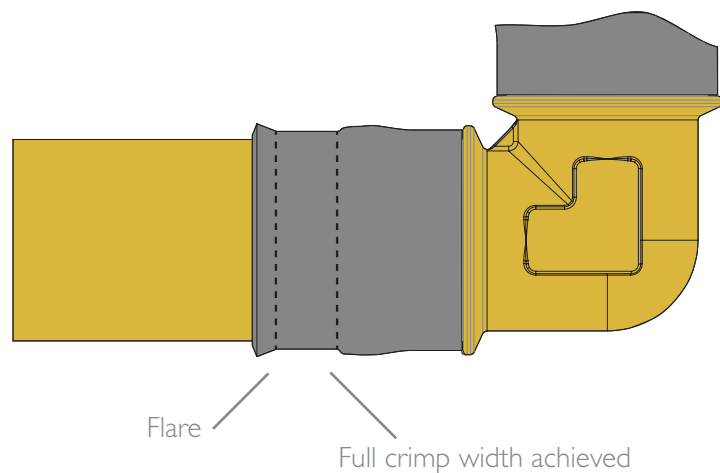

- (d) Be methodical and ensure you clamp all fittings on the job.

Pipelife Polymer Threaded Connections

- (a) It is essential to use pipe thread tape - use a small amount and wrap correctly onto male thread connectors to ensure an adequate protection against leaking and contact with brass or galvanised material.
- (b) Avoid using liquid thread sealer compounds on Qual-PEX Crimp polymer threaded fittings.
- (c) DO NOT OVERTIGHTEN AS THREADS ARE TAPERED and therefore will tighten with less turns compared to male parallel threads.



Qual-PEX Crimp Tap Connectors

- (a) Ensure that when using a tap connector, the shoulder is presented squarely to a flat machined face before tightening. This avoids crossed threads and ensures a seal. No (PTFE) pipe thread tape or sealant required.



Installing Qual-PEX Crimp System in Concrete / Masonry

- (a) Use a pipe sleeve when burying Qual-PEX pipe in concrete. Pipe sleeves should be large enough to allow free movement for expansion and contraction. Please see our Qual-PEX Pipe-in-Pipe range.
- (b) A pipe sleeve is not required when installing a low temperature / pressure underfloor heating system (refer to manufacturer).
- (c) It is recommended that no joints be used when Qual-PEX pipe is installed in concrete slabs, footings etc. and must be in accordance with local building codes - be sure to check.
- (d) When installing in concrete / cement plastered walls, use a pipe sleeve to allow free movement for expansion and contraction.



If jointing is necessary, or if the fittings will come in contact with cement, lime or soil, wrap the aluminium rings directly and completely using polythene building tape or PVC insulation tape or similar. Also, allow 1% for expansion and contraction.



“Feeding” Qual-PEX Pipe Through Timbers

- (a) “Pipe sleeves” and bored holes should be large enough to allow free movement of Qual-PEX pipe.
Minimum Hole Sizes:
Use 18mm drills for 1/2” pipe.
Use 24mm drills for 3/4” pipe.
- (b) Larger holes may be required to ease pipe through if changing direction.
- (c) Use of silicone in the holes is not required.

Qual-PEX Pipe Specifications

Qual-PEX is a cross-linked high-density polyethylene. Cross-linking is a widely employed method of forging permanent links between polymer chains to form an interwoven three dimensional lattice within the pipe wall. This greatly reduces the ability of the polymer to 'creep' with time and allows the burst resistance of Qual-PEX to be maintained almost indefinitely at high temperatures.

Irish Dimensions	½”	¾”	1”
Outside diameter (mm)	14.63 - 14.74	20.98 - 21.09	27.33 - 27.44
Wall thickness (mm)	1.6 - 1.8	2.05-2.25	2.60-2.80
Weight / 100 (meters)	6.7kg	12.3kg	20.0kg
Standard lengths	3m&6m	3m&6m	3m&6m
Standard coils (meters)	100m	50m	50m

Qual-PEX Crimp System - Approvals and Testing

Qual-PEX barrier pipe is IAB approved in addition to meeting the requirements for the class 5 service conditions as specified in EN 15875 for a service life of 50 years. The Qual-PEX crimp system has been successfully tested in accordance with relevant national and international requirements and has been extensively tested for long term durability, pressure resistance, thermo-stability and leak-tightness. Consequently, the Qual-PEX crimp system offers a reliable, dependable plumbing solution giving superb system performance and durability over the long term service life for central heating, underfloor heating and hot and cold water system applications.

Type Testing and Assessments

The Qual-PEX crimp system has been successfully subjected to long term hydrostatic pressure resistance testing, appropriate thermal cycling of assembled joints, resistance to pull-out of assembled joints, resistance to cyclic pressure shock and short term hydrostatic pressure resistance at 20°C and 82°C.

Quality Control Testing

Qual-PEX pipe and crimp fittings are manufactured under ISO 9001 approved Quality Management Systems. Continuous batch sampling during normal production and rigorous testing ensures the crimp system meets specifications for mechanical strength at elevated temperatures and pressures including resistance to long-term degradation.

Expansion and Contraction

Compared with steel or copper, all PEX pipes have a high coefficient of expansion and precautions should be taken to compensate for this. The coefficient of expansion for Qual-PEX increases from about $1.5 \times 10^{-4} \text{m}/^\circ\text{C}$ at 20°C to approximately $2.8 \times 10^{-4} \text{m}/^\circ\text{C}$ at 82°C.

N.B. Allow for 1% expansion on the length when pipe is installed at 20°C for use up to 82°C. (82°C being the recommended maximum working pressure of the heating system (radiators)).

Where Qual-PEX is to be surface mounted and used in visible situations for either hot-water supply or central-heating pipework, long straight runs should be avoided since some distortion may occur. Where this is not practicable, pipework should be boxed.

Care should be taken at all times to ensure that pipework is laid out to allow for expansion and contraction. Where appropriate, expansion loops may be employed.

Pipe Clipping

Pipe clips and trunking systems designed for use with copper tube may also be used with Qual-PEX. Clips should be positioned adjacent to fittings wherever possible, making due allowance for expansion and contraction of the pipework. Where Qual-PEX is to be surface mounted and visible, the following clipping distances are recommended:

Average Service Temperature

½" Qual-PEX	20°C	60°	80°
horizontal	500mm	400mm	300mm
vertical	800mm	600mm	500mm
¾ " Qual-PEX			
horizontal	800mm	600mm	500mm
vertical	1200mm	1000mm	800mm

Where Qual-PEX is to be boxed in or installed under floors or in loft spaces etc, clipping distances can be increased, or the clips omitted altogether if the pipe is adequately supported by other means. Even if Qual-PEX dips slightly between the joints, the speed of water created by the pump is sufficient to move any bubbles of air that may be present in the system. Pump speeds of 1.5m/s may be used with Qual-PEX without causing undue noise.

Minimum Bend Radii

1/2" Qual PEX	100 mm using pipe clips
3/4" Qual PEX	175 mm using pipe clips

Storage and Handling

- (a) Store fittings so that they cannot be damaged by heavy tools, etc. It is a good idea to have a tool box to carry the large range of fittings available.
- (b) Take care to keep the Qual-PEX Plumbing System away from chemicals, solvents, cements, oxidising agents or petroleum products.
- (c) Store the Qual-PEX Crimp system away from direct sunlight and high temperature sources.

N.B. A minimum of 1m of copper tube is required between the boiler connection and Qual-PEX.

UV Exposure

The Qual-PEX Crimp System should be adequately protected against exposure to direct sunlight when located (either vertically or horizontally) on the exterior of a building.

Freezing Conditions

Qual-PEX pipe is the best choice for water distribution in climates where freezing conditions are likely to be encountered. Qual-PEX pipe will absorb the expansion of frozen water within itself more than any other pipe. However, insulation should be used where the possibility of freezing may occur. The insulation will also minimize heat loss and conserve energy. Please see our Qual-PEX Eco range.

Working Conditions

Extensive tests have shown that Pipelife products will withstand temperatures and pressures in excess of normal working conditions. Pipelife's Qual-PEX CRIMP system should be installed to conform with good plumbing practice.

USUAL WORKING TEMPERATURES	
Application	Usual working temperature °C
Cold Water	20
Central Heating	82
Hot Water	65

N.B.
The maximum operating temperature for the Qual-PEX Crimp System is 82°C. Please ensure that the system is suitably calibrated not to exceed these conditions.

Pipelife Qual-PEX CRIMP system has a recommended service operating temperature of 82°C and it is not recommended for applications where the continuous operating temperature may exceed this limit.

Circulating Main Installations

A continuously operated re-circulating system is a water replenished circulating system which is maintained at a constant high temperature to provide a constant source of hot water. Continuously operated re-circulating systems are used to distribute constant hot water to draw off points that may be distant from the source or hot water storage vessel. Continuously operated recirculating systems are very different from conventional hot water supply and central heating systems found in domestic properties, for which our products have been tested, and for this reason Qual-PEX pipe/Qual-PEX Crimp fittings must not be used on any continuously operated re-circulating systems.

Hot Water Installations

- (a) Qual-PEX installations should have a minimum of 1 metre of copper tube from the hot water cylinder.
- (b) All installations supplying hot water that are to be utilised for personal hygiene require a temperature limiting valve to be installed on the outlet side of the hot water cylinder. This ensures safe temperatures for the householder at the tap.
- (c) When commissioning the plumbing system, set and test the temperature of the hot water cylinder. Hot water cylinder thermostats should be set at a maximum of 65°C as part of the test procedure.

With a setting of 65°C the hot water system can be maintained within operating requirements and a long service life is expected for the complete plumbing system.

Boiler and Cylinder Connections

General Requirements

A minimum of 1M of copper tube is required between the boiler connections and QUAL-PEX. All systems should incorporate a boiler thermostat set to normal working conditions (82 degrees C), as well as a high limit thermostat, a 3 bar safety valve, adequate expansion allowance, and they should be fitted to manufacturer's installation guidelines.

Specific Requirements

Low water content boilers with cast iron heat exchangers

A minimum of 1 metre of copper tube is required between the boiler connections and Qual-PEX. Furthermore a permanent by-pass must be fitted directly after the pump between the main flow and return pipes to allow the pump to dissipate residual heat from the boiler under all circumstances.

All pipework between the boiler and the safety valve should be installed using copper tube. Where zone controls or thermostatic radiator valves which may cause a reduction in water flow rates through the boiler are installed, a permanent by-pass should be installed between the main flow and return pipework. Installers should ensure that the system is properly filled and vented during the commissioning stage before the boiler is operated.

Note: Pipelife recommends that the balancing valve for the hot water circuit be a brass lockshield gate valve (conforming to BS 5154).

Pressure Testing

To ensure the connections have made a full seal and that the pipe or fittings have not been damaged during installation a pressure test of 6-bar must be carried out for one hour. Once successful the pressure is dropped to 3-bar and allowed stand (during the pour) until second fixing.

Installation Checklist for the Complete System

Be methodical and check as you go that each joint has been clamped correctly as per recommended guidelines.

- ✓ Check the pipe is clean and in good condition.
- ✓ Check that pipework is "clipped" and supported.
- ✓ Check for expansion and contraction allowance on pipes.
- ✓ Pressure test the system cold at 6 bar for 1 hour and leave stand at 3 bar.
- ✓ Set the temperature to a maximum of 82°C.
- ✓ Check the hot water temperature is 65°C.

Some Questions Most Often Asked About Qual-PEX and the Crimp System

Q: Is Qual-PEX AND THE Qual-PEX CRIMP system approved for drinking water?

A: Yes. Qual-PEX systems are specifically tested and approved to carry drinking water by WRAS.

Q: Can Qual-PEX CRIMP System be buried in concrete?

A: If it is necessary to make a joint in concrete, allow 1% for expansion and contraction. It is also necessary to completely cover the aluminium ring so it does NOT come in contact with the concrete

Q: Does Qual-PEX CRIMP system require lagging under floors?

A: Lagging is not required under intermediate floors, but should be used where Qual-PEX is run under ground floors or in unheated spaces, for frost protection and energy conservation. Heat loss is less from Qual-PEX than from rigid pipes, and Qual-PEX is resistant to bursting down to -20°C.

Q: Does the Qual-PEX CRIMP System reduce installation time and cost?

A: Yes. Once the installer gets used to working with the Qual-PEX CRIMP System, up to 20% savings can be made in the labour content alone.

Q: Can inhibitors be used on Qual-PEX CRIMP System?

A: Yes. Inhibitors are recommended for all heating systems.

Q: What effect does hard water have on the Qual-PEX CRIMP System?

A: The smooth bore and flexibility of Qual-PEX prevents lime scale adhering to the inner surface of the pipe.

Q: What effect does soft water have on the Qual-PEX CRIMP System?

A: None. Unlike rigid metal pipes, the Qual-PEX CRIMP System is not dissolved or corroded by soft acidic water.

Q: Can the Qual-PEX CRIMP System be used on solid fuel central heating systems?

A: Qual-PEX CRIMP System can be used on the secondary side of a solid fuel heating system. Qual-PEX should not be used for primary pipework on gravity systems.

Q: Can Qual-PEX CRIMP System be used on sealed central heating systems?

A: Yes, provided that usual working temperatures of 82 degrees are not exceeded.

Q: Can Qual-PEX Crimp System be painted?

A: Yes. Qual-PEX CRIMP System can be painted, using water based paints.

Q: Can pipe jointing compounds be used with Qual-PEX?

A: Yes. Both Boss White and Foliac compounds have tested satisfactorily with Qual-PEX only on compression and threaded joints. No jointing compounds are required on the Qual-PEX crimp system other than PTFE tape on threaded joints.

Some Questions Most Often Asked About Qual-PEX and the Crimp System (continued)

Q: Can Qual-PEX CRIMP System be used for gas pipe or for carrying oil?

A: No. Qual-PEX CRIMP System is only guaranteed for use with water.

Q: Is the Qual-PEX CRIMP System subject to damage if flux ingress arises from soldered fittings?

A: Yes, no fluxes of any type should come in contact with Pipelife Ireland pipe and fittings. If fluxes are to be used in an environment where our fittings are installed, then extreme care should be taken to ensure that no such contact takes place.

Q: Do Pipelife have any guidance or recommendations with regard to ClO₂ (chlorine dioxide) levels?

A: Yes, Pipelife Ireland pipe and fittings are not suitable for use in systems which have high concentrations of chlorine, e.g. swimming pools. Short term chlorination for disinfection will not have an adverse effect on the system. Sustained exposure to chlorine levels above 0.5ppm should be avoided, however these concentrations do not normally arise in potable water supplies.

Q: Do Pipelife have any guidance or recommendations with regard to the use of trace heating tapes?

A: Trace heating tape has no adverse reaction on Pipelife PB, or PEX, pipe as long as it does not exceed the maximum temperatures as per Pipelife guidelines. Trace heating generally works on very low temperatures, and will be well below the maximum temperatures recommended by Pipelife.

Q: Do Pipelife recommend pressure testing with Air or Water?

A: We do not recommend pressure testing of joints with compressed air, only water for pressure system testing. Water will detect any leaks and is far safer. N.B. In winter, (freezing conditions), due care must be taken to avoid damage to pipes in the event of water freezing in the pipes. This causes catastrophic damage to PEX pipes. Refer to BS EN 806.

Q: What are the fittings made from?

A: The polymer fittings are made from a high performance thermoplastic. The polymer fittings can withstand high temperatures and will not corrode. The aluminium is annealed (heat treated) and is also air force grade.

Q: Where are the fittings manufactured?

A: The fittings are made in New Zealand by the largest plumbing and heating pipe and fitting manufacturer in that country. The Qual-PEX pipe is manufactured in Cork, Ireland.

Q: Can the Qual-PEX CRIMP fittings be used with other pipes?

A: The Qual-PEX CRIMP fittings are not approved for use with copper, stainless steel or non Qual-PEX pipes. The Qual-PEX CRIMP fittings are only approved with Pipelife Qual-PEX Irish sizes.

About Pipelife

Pipelife Ireland Limited has been in the business of producing quality goods for the Plumbing, Construction and Agricultural sectors for more than forty five years, specialising in the extrusion of polyethylene pipe for these applications. The product range has evolved over this time to the latest generation of Qual-PEX thermoplastic pipes which can carry Hot and Cold Water.

As well as being a leading edge manufacturer (ISO 9001 certified) of pipe for the Plumbing and Heating Industry, Pipelife has developed a true expertise in the design of heating systems to maximize the potential of Qual-PEX pipe. Many systems are straight-forward and are simply adapted from traditional metal pipe plumbing systems, but new methods of heating buildings have now been adapted with the use of thermoplastic pipe in applications such as wall heating, ceiling heating and most especially Underfloor Heating.

The Qual-PEX CRIMP fitting has been specifically designed for use with Qual-PEX pipe.



• TOUGH • DEPENDABLE • LONG LASTING (50 YEAR WARRANTY)



Pipelife Ireland Ltd,
White's Cross, Cork.
Phone: 021-4884700
Fax: 021-4884701
Email: ireland@pipelife.com
www.pipelife.com